

**RS-9110-N-11-24 Self Contained
802.11 b/g/n Module with
Networking Stack**

Datasheet

Version 2.3

September 2013

Redpine Signals, Inc.

2107 N. First Street, #680

San Jose, CA 95131.

Tel: (408) 748-3385

Fax: (408) 705-2019

Email: info@redpinesignals.com

Website: www.redpinesignals.com

The RS9110-N-11-24 module is a IEEE 802.11bgn based WLAN device that directly provides a wireless interface to any equipment with a UART or SPI interface for data transfer. It integrates a MAC, baseband processor, RF transceiver with power amplifier in hardware; and all WLAN protocol and configuration functionality, networking stack in embedded firmware to make a fully self-contained 802.11n WLAN solution for a variety of applications.

Applications:

- Seamless Wi-Fi connectivity for Application Processors
- Industrial M2M communications
- Point of Sale Terminals
- Metering (Parking Meters, Utility Meters, Power Meters, etc.)
- Security Cameras and Surveillance Equipment
- Logistics and Freight Management
- Warehousing
- Digital Picture Frames

- Several medical applications including Patient Monitoring, Remote Diagnostics

Device Features:

- 802.11b/g and single stream 802.11n module
- Supports WPA2-PSK, WEP (64 and 128 bit) and TKIP security in infrastructure mode
- Supports WEP (64 and 128 bit) mode of security in ad-hoc mode
- Host interface through UART and SPI
- Integrated TCP/IP stack with option to bypass the stack in SPI mode
- Ultra-low-power operation with power-save modes
- Ad-hoc and infrastructure modes for maximum deployment flexibility
- Configure module wirelessly for easy field deployment, in SPI mode
- Single supply – 3.1 to 3.6V operation
- Pad for external antenna connection
- Device Dimensions 13.7 mm x 12.9 mm x 1.7mm

RS9110-N-11-24 System Block Diagram

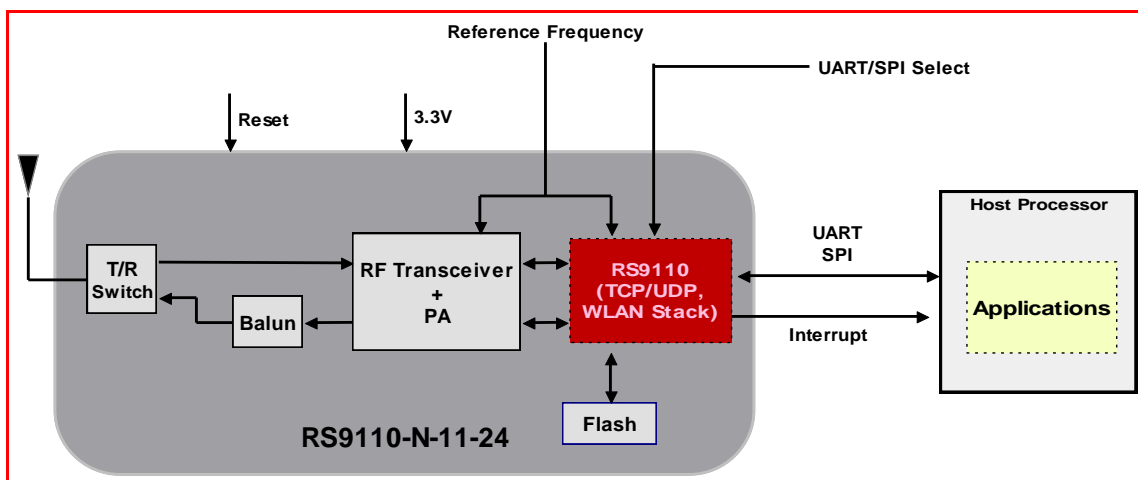

Table of Contents

RS-9110-N-11-24 Self Contained 802.11 b/g/n Module with Networking Stack	1
1: Detailed Feature List	7
1.1: Host Interfaces	7
1.2: WLAN	7
1.2.1: MAC	7
1.2.2: Baseband Processing	7
1.2.3: RF	7
1.3: Networking Protocols	7
1.4: Configuration	8
1.5: Software	8
1.6: Compliance and Certification	8
2: Package Description	9
2.1: Top View	9
2.2: Bottom View	9
2.3: Package Dimensions	10
2.4: PCB Landing Pattern	11
2.5: Recommended Reflow Profile	12
2.6: Baking Instructions	12
3: Pin Description	13
3.1: Module Pinout	13
3.2: Pin Description	13
4: Electrical Characteristics	18
4.1: Absolute Maximum Ratings	18
4.2: Recommended Operating Conditions	18
4.3: DC Characteristics – Digital I/O Signals	18
4.4: AC Characteristics – Digital I/O Signals	19
4.4.1: SPI Interface	19
5: Reset Sequence and Timing	20
6: Performance Specifications	21
6.1: Wireless Specifications	21
6.2: Receive Characteristics	21
6.2.1: Sensitivity	21
6.3: Throughput	21
6.4: Range	22
6.5: Standards Compliance	22
7: Software Architecture Overview	23
7.1: Host	24
7.1.1: UART	24
7.1.2: SPI	24
7.1.3: Thin SPI Driver	24
7.2: RS9110-N-11-24	24
7.2.1: SPI	24

7.2.2: UART.....	24
7.2.3: Host Abstraction Layer (HAL)	25
7.2.4: Wireless Control Block (WCB).....	25
7.2.4.1: TCP/IP Control frames.....	25
7.2.5: Station Management Entity (SME)	25
7.2.6: WPA Supplicant	25
7.2.7: Power Save Modes.....	25
7.2.7.1: Power mode 0.....	25
7.2.7.2: Power mode 1.....	25
7.2.7.3: Power mode 2.....	26
8: Ordering Information	27
9: Command Reference (AT commands and SPI commands)..	28

Table of Figures

Figure 1: Top View of the Module	9
Figure 2: Bottom View of the Module	9
Figure 3: Package Dimensions.....	10
Figure 4: PCB Landing Pattern.....	11
Figure 5: Reflow Profile.....	12
Figure 6: Pinout of the Module	13
Figure 7: Interface Timings – SPI Interface	19
Figure 8: Reset Pin Timing Diagram	20
Figure 9: RS9110-N-11-24 Software Architecture Block Diagram	23

List of Tables

Table 1: Absolute Maximum Ratings..... 18
Table 2: Recommended Operating Conditions 18
Table 3: Input/Output DC Characteristics 19
Table 4: AC Characteristics – SPI Interface..... 19
Table 5: Wireless Specification..... 21
Table 6: Receive sensitivity 21
Table 7: Device Ordering Information 27

1: Detailed Feature List

1.1: Host Interfaces

- UART
 - The UART interface supports standard baud rates from 9600 to 3686400 bps
 - AT Command Interface for configuration and operating the module
- SPI Interface
 - Standard 4-wire SPI
 - Operation up to a maximum clock speed of 25 MHz

1.2: WLAN

1.2.1: MAC

- Conforms to IEEE 802.11b/g/n standards for MAC
- Dynamic selection of fragment threshold, data rate depending on the channel statistics
- Hardware accelerated implementation for AES
- WPA2 and WEP support
- Infrastructure and Ad-hoc modes

1.2.2: Baseband Processing

- Supports DSSS (1, 2 Mbps) and CCK (5.5, 11 Mbps) modes
- Supports all OFDM data rates (6, 9, 12, 18, 24, 36, 48, and 54 Mbps)
- Supports IEEE 802.11n single-stream modes with data rates up to 65 Mbps
- Supports long, short, and HT preamble modes
- High-performance multipath compensation in OFDM, DSSS, and CCK modes

1.2.3: RF

- Highly integrated 2.4 GHz transceiver with direct conversion architecture
- Receiver with 38 dB RF selectable gain range and 60 dB baseband variable gain range
- Power amplifier with a typical output power of 17 dBm for 11b and 15 dBm for 11g and 11n respectively. Please refer Table 5 [Wireless Specification](#), pp 21.
- Integrated LNA, BPF, and T/R switch

1.3: Networking Protocols

- TCP
- UDP

- ARP
- ICMP
- DHCP

The RS9110-N-11-24 comes with flexible frameworks to enable usage in various application scenarios, viz., high throughput, more network features, etc. Please contact Redpine for addition of network features like HTTP server.

1.4: Configuration

The RS9110-N-11-24 module can be configured through UART or SPI. The following are some of the commands that can be given to the module:

- Scan
- Connect
- Pre-shared Keys
- SSID of hidden WLAN networks
- DHCP Enable/Disable
- Create/Join an IBSS network
- Open/Close sockets for TCP, UDP, Listening TCP

1.5: Software

- Sample Host driver for SPI
- Configuration and management GUI for Windows XP for UART
- Embedded software for complete WLAN functionality including 802.11n aggregation and Block-ACK, auto rate adaptation, security and also complete network stack and applications including TCP, UDP, ARP, ICMP, DHCP.
- The module, in SPI mode, can be made to come up as an Access point, to which a standard WLAN device such as a laptop can connect and configure the module or upgrade the firmware

1.6: Compliance and Certification

- RS9110-N-11-24 is identical in hardware to RS9110-N-02 module which is FCC, IC, and CE certified. RF Testing Software is provided for any end product certification requirements.
- RoHS (Restriction of Hazardous Substances) compliant

2: Package Description

2.1: Top View



Figure 1: Top View of the Module

2.2: Bottom View

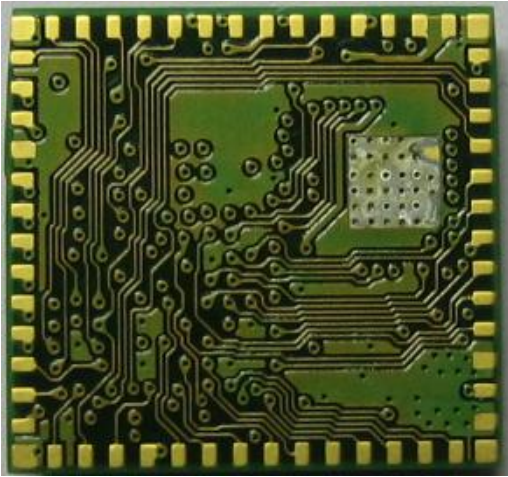

Figure 2: Bottom View of the Module

2.3: Package Dimensions

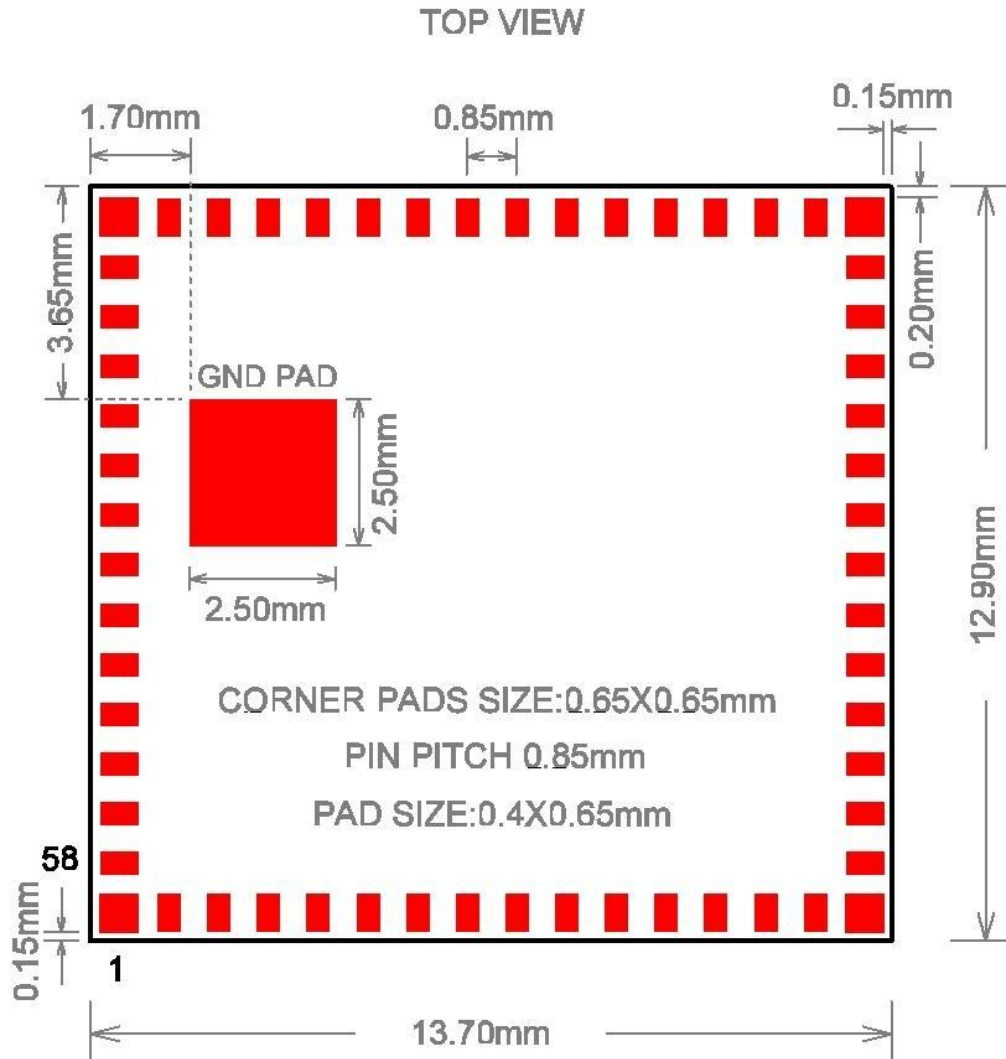

Figure 3: Package Dimensions

Module Height = 1.7 mm

2.4: PCB Landing Pattern

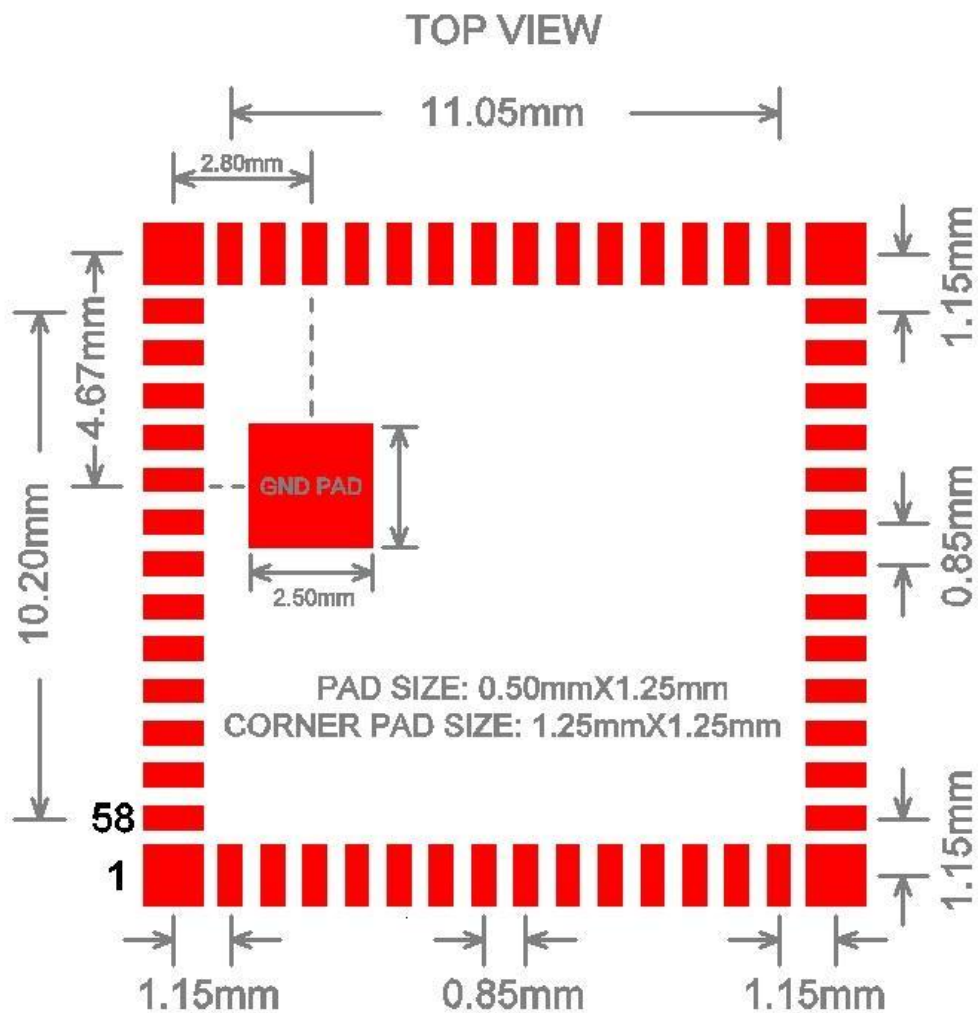

Figure 4: PCB Landing Pattern

2.5: Recommended Reflow Profile

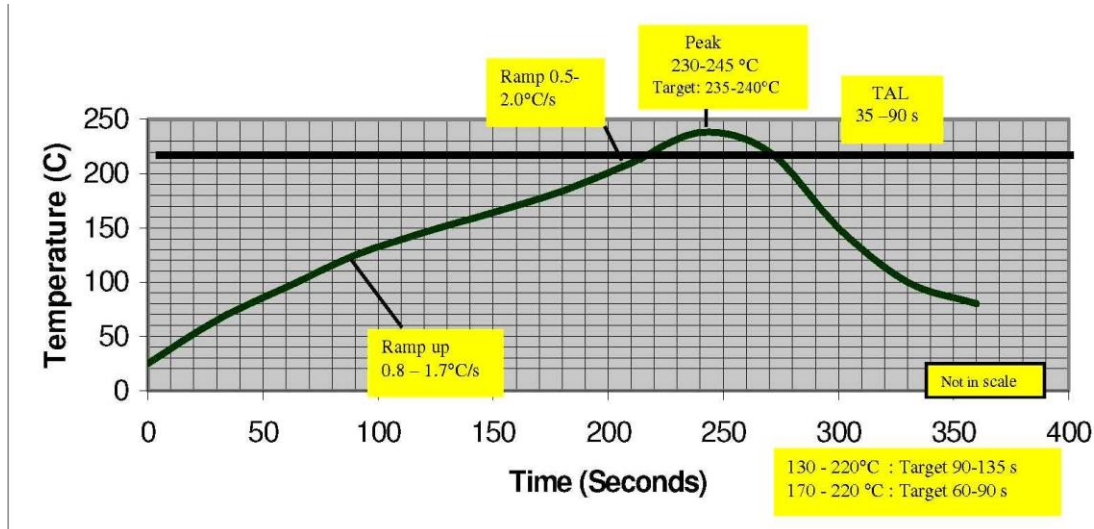

Figure 5: Reflow Profile

Note: The profile shown is based on SAC 305 solder (3% silver, 0.5% copper). We recommend the ALPHA OM-338 lead-free solder paste. This profile is provided mainly for guidance. The total dwell time depends on the thermal mass of the assembled board and the sensitivity of the components on it.

2.6: Baking Instructions

The RS9110-N-11-24 package is moisture sensitive and devices must be handled appropriately. After the devices are removed from their vacuum sealed packs, they should be taken through reflow for board assembly within 168 hours at room conditions, or stored at under 10% relative humidity. If these conditions are not met, the devices must be baked before reflow. The recommended baking time is nine hours at 125° C.

3: Pin Description

3.1: Module Pinout

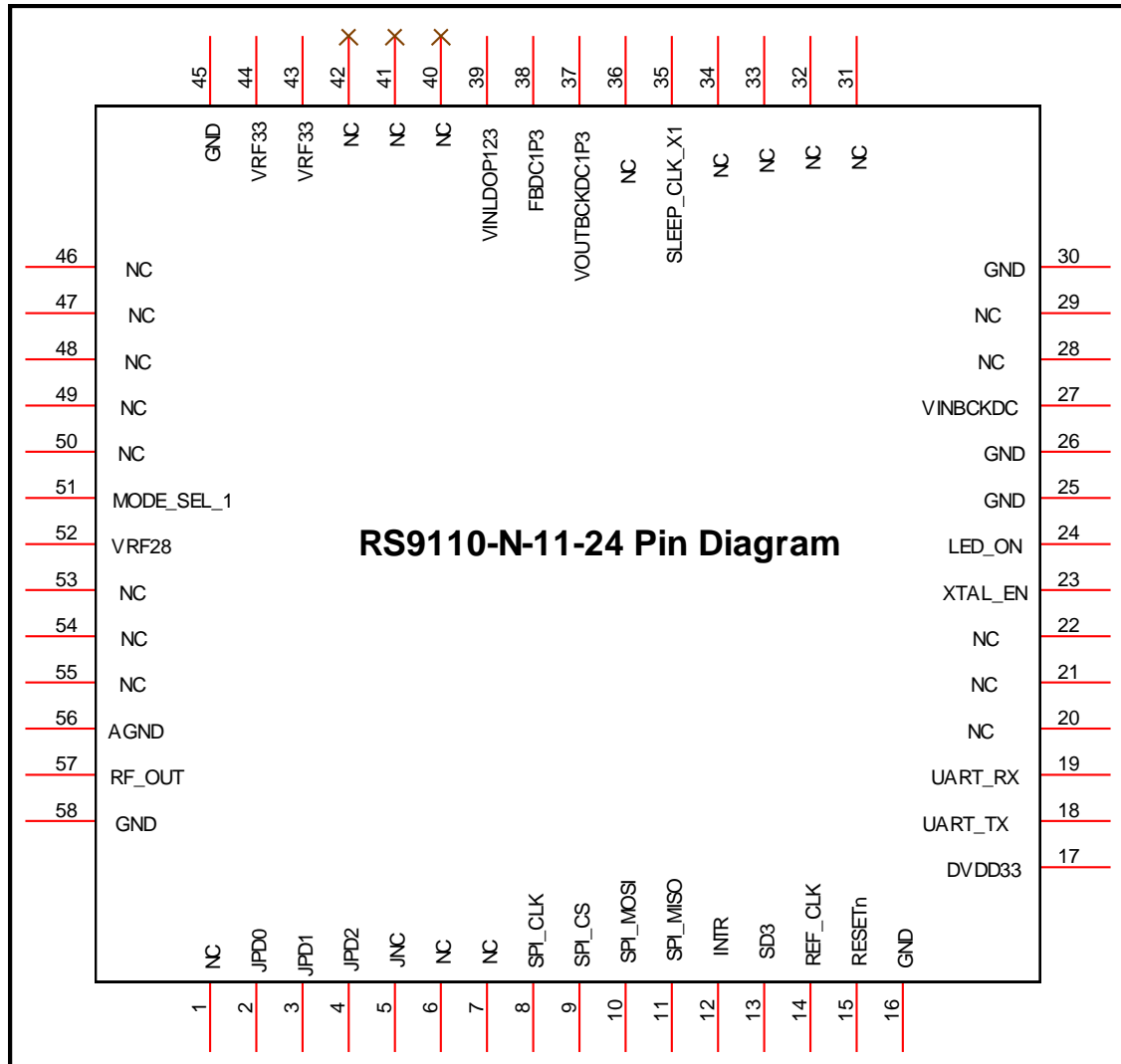

Figure 6: Pinout of the Module

3.2: Pin Description

Pin No.	Pin Name	Direction	TYPE	Description
1	NC	-		No connect
2	JPD0	-		Connect pull down of 1K Ohms
3	JPD1	-		Connect pull down of 1K Ohms
4	JPD2	-		Connect pull down of 1K Ohms

**RS-9110-N-11-24 Self Contained 802.11 b/g/n
Module with Networking Stack
Datasheet
Version 2.3**



Pin No.	Pin Name	Direction	TYPE	Description
5	JNC	-		No connect
6	NC	-		No connect
7	NC	-		No connect
8	SPI_CLK	Input	LVC MOS	SPI Clock input. SPI Data Input. In UART mode, connect pull-down (1K to 10K Ohms)
9	SPI_CS	Input	LVC MOS 8mA	Active low SPI Chip Select. SPI Data Input. In UART mode, connect pull-down (1K to 10K Ohms)
10	SPI_MOSI	Input	LVC MOS 8mA	SPI Data Input. In UART mode, connect pull-down (1K to 10K Ohms)
11	SPI_MISO	Output	LVC MOS 8mA	SPI Data output. No connect in UART mode.
12	INTR	Output	LVC MOS 8mA	Interrupt to the host. Active high, level triggered. Asserted by the module when: 1.The module has to transmit data to the host through SPI 2.When the module wakes up from sleep mode
13	SD3	-		No connect in SPI mode. In UART mode, connect pull-down (1K to 10K Ohms)
14	REF_CLK	Input		Reference Clock source: 40 MHz.
15	RESET_n	Input	LVC MOS	Power-on reset. Active low, and required to be active for at least 10 ms
16	GND	Ground		Ground. Ground. Connect all the GND pins directly to a ground plane or copper ground fill
17	DVDD33	Power		3.3 Volts Input to the I/O Rail
18	UART_TX	Output	LVC MOS 4mA	UART output. No connect in SPI mode.
19	UART_RX	Input	LVC MOS 4mA	UART input. No connect in SPI mode.
20	NC	-		No connect

**RS-9110-N-11-24 Self Contained 802.11 b/g/n
Module with Networking Stack
Datasheet
Version 2.3**



Pin No.	Pin Name	Direction	TYPE	Description
21	NC	-		No connect
22	NC	-		No connect
23	XTAL_EN	Output	LVC MOS 4mA	This signal controls an external reference clock oscillator for power-save purposes. 1 – Enable 0 – Disable
24	LED_ON	Inout	LVC MOS 4mA	LED Control signal. Indicates successful firmware download – the device pulls this line low when the module is activated. To be connected to the Cathode of an LED with a recommended series resistor of 820 ohms to VDD.
25	GND	Ground		Ground. Connect all the GND pins directly to a ground plane or copper ground fill
26	GND	Ground		Ground. Connect all the GND pins directly to a ground plane or copper ground fill
27	VINBCKDC	Power		3.3 Volts input to the RS9110-N-11-24's PMU
28	NC	-		No connect
29	NC	-		No connect
30	GND	Ground		Ground. Ground. Connect all the GND pins directly to a ground plane or copper ground fill
31	NC	-		No connect
32	NC	-		No connect
33	NC	-		No connect
34	NC	-		No connect
35	SLEEP_CLK_X1	-		Ground.
36	NC	-		No connect
37	VOUTBCKDC1P3	Power		Internal DC-DC convertor output. A Schottky diode is to be placed on this line for protection.

**RS-9110-N-11-24 Self Contained 802.11 b/g/n
Module with Networking Stack
Datasheet
Version 2.3**



Pin No.	Pin Name	Direction	TYPE	Description
38	FBDC1P3	Power		Feedback for the DC-DC Converter
39	VINLDOP123	Power		Input to the LDO's. Connect this to FBDC1P3.
40	NC	-		No connect
41	NC	-		No connect
42	NC	-		No connect
43	VRF33	Power		3.3 Volts input to the RF transceiver
44	VRF33	Power		3.3 Volts input to the RF transceiver
45	GND	Ground		Ground. Ground. Connect all the GND pins directly to a ground plane or copper ground fill
46	NC	-		No connect
47	NC	-		No connect
48	NC	-		No connect
49	NC	-		No connect
50	NC	-		No connect
51	MODE_SEL_1	Input	LVC MOS 2mA	SPI Mode: Connect pull down (3.9K Ohms to 4.7K Ohms) UART Mode: No connect
52	VRF28	Power		2.8 Volts LDO O/P
53	NC	-		No connect
54	NC	-		No connect
55	NC	-		No connect
56	GND	Ground		Ground. Ground. Connect all the GND pins directly to a ground plane or copper ground fill
57	RF_OUT	Rfin/Rfout		Antenna Port-50 ohms Impedance
58	GND	Ground		Ground. Ground. Connect all the GND pins directly to a ground plane or copper ground fill

**RS-9110-N-11-24 Self Contained 802.11 b/g/n
Module with Networking Stack
Datasheet
Version 2.3**



Notes:

- Please contact Redpine Signals for application notes or for customization of a solution.

4: Electrical Characteristics

4.1: Absolute Maximum Ratings

Absolute maximum ratings in the table given below are the values beyond which the device could be damaged. Functional operation at these conditions or beyond these conditions is not guaranteed.

Parameter	Symbol	Value	Units
Input Supply voltage	V _{in}	3.6	V
Supply voltage for I/O Rail	DVDD33	3.6	V
Supply Voltage for the RF	VRF33	3.6	V
RF Input Level	RFIN	10	dBm
Storage temperature	T _{store}	-65 to 150	°C
Electrostatic discharge tolerance (HBM)	ESD _{HBM}	2000	V
Electrostatic discharge tolerance (MM)	ESD _{MM}	200	V
Electrostatic discharge tolerance (CDM)	ESD _{CDM}	500	V

Table 1: Absolute Maximum Ratings

4.2: Recommended Operating Conditions

Parameter	Symbol	Min.	Typ.	Max.	Units
Input Supply voltage	V _{IN}	3.1	3.3	3.6	V
Supply voltage for I/O Rail	DVDD33	3.1	3.3	3.6	V
Supply Voltage for the RF	VRF33	3.1	3.3	3.6	V
Ambient temperature	T _a	-40	25	85	°C

Table 2: Recommended Operating Conditions

4.3: DC Characteristics – Digital I/O Signals

Parameter	Min.	Typ.	Max.	Units
Input high voltage	2	-	3.6	V
Input low voltage	-0.3	-	0.8	V
Output low voltage	-	-	0.4	V
Output high voltage	2.4	-	-	V
Input leakage current (at 3.3V or 0V)	-	-	±10	μA

Parameter	Min.	Typ.	Max.	Units
Tristate output leakage current (at 3.3V or 0V)	-	-	±10	μA

Table 3: Input/Output DC Characteristics

4.4: AC Characteristics – Digital I/O Signals

4.4.1: SPI Interface

Parameter	Symbol	Min.	Typ.	Max.	Units
SPI_CLK Frequency	Fspi	0		25	MHz
SPI_CS to output valid	Tcs	3.5	-	7.5	ns
SPI CS, setup time	Tcst	2	-		ns
SPI_MOSI setup time	Tsd	1	-		ns
SPI_MOSI hold time	Thd	1.5	-		ns
SPI_MISO clock to output valid	Tod	4	-	9.25	ns

Table 4: AC Characteristics – SPI Interface

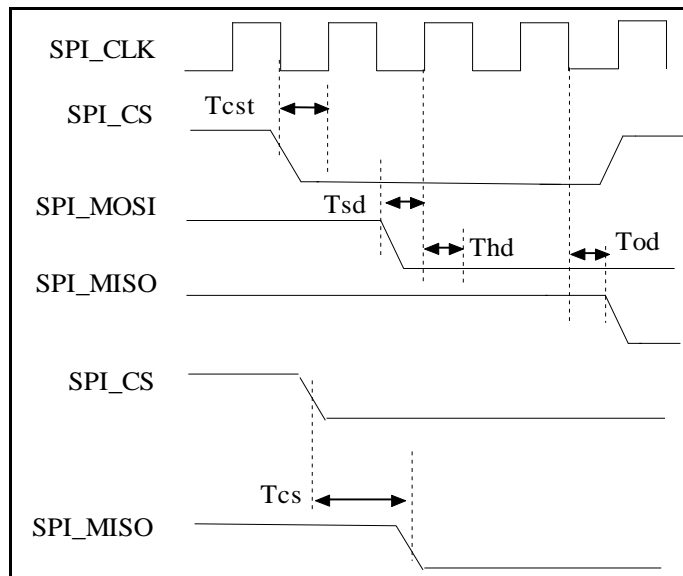

Figure 7: Interface Timings – SPI Interface

5: Reset Sequence and Timing

Following diagram shows the timing requirement for Reset_n input in two scenarios. This timing is valid for both UART and SPI based modules. The crystal oscillator output should be stable before releasing reset.

- A. Powerup
- B. Giving hard reset during module operation

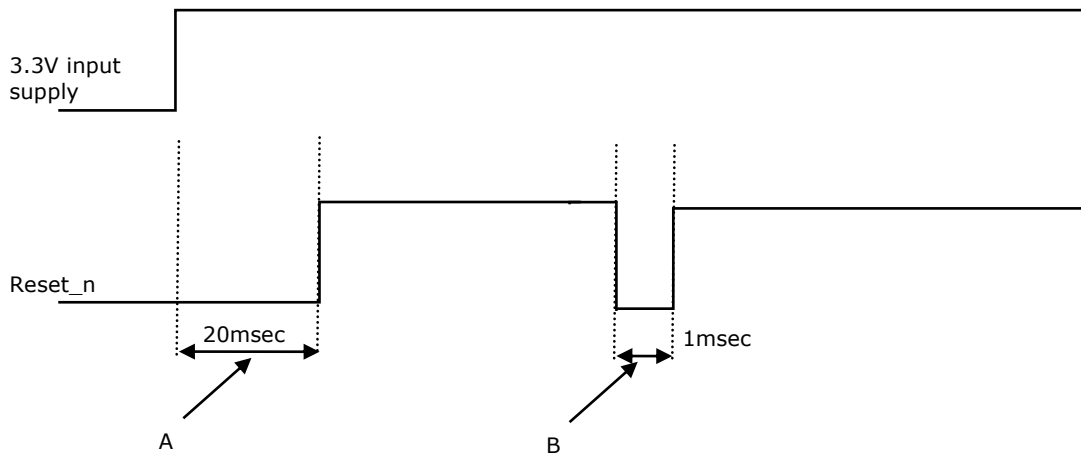

Figure 8: Reset Pin Timing Diagram

6: Performance Specifications

6.1: Wireless Specifications

Feature	Description
Frequency Band	2.400 – 2.500 GHz (2.4 GHz ISM band)
Frequency Reference	40 MHz
Modulation	OFDM with BPSK, QPSK, 16-QAM, and 64-QAM 802.11b with CCK and DSSS
Supported Data Rates	802.11n: 6.5, 13, 19.5, 26, 39, 52, 58.5, 65 Mbps 802.11g: 6, 9, 12, 18, 24, 36, 48, 54 Mbps 802.11b: 1, 2, 5.5, 11 Mbps
802.11n Features	MCS 0-7, STBC, RIFS, Greenfield Protection A-MPDU, A-MSDU Aggregation with Block-ack
Typical Transmit Power (+/- 2 dBm)	17 dBm for 802.11b DSSS 17 dBm for 802.11b CCK 15 dBm for 802.11g/n OFDM

Table 5: Wireless Specification

6.2: Receive Characteristics

6.2.1: Sensitivity

Data Rate	Typical Sensitivity (+/- 1.5 dBm)
1 Mbps	-97.0 dBm (< 8% PER)
2 Mbps	-93.0 dBm (< 8% PER)
11 Mbps	-88.9 dBm (< 8% PER)
6 Mbps	-91.0 dBm (<10% PER)
54 Mbps	-75.0 dBm (< 10% PER)
65 Mbps	-71.0 dBm (< 10% PER)

Table 6: Receive sensitivity

6.3: Throughput

Interface	(TCP) Throughput
UART (measured at 115200 bauds per sec)	Tx – 75 kbps Rx – 72 kbps

Interface	(TCP) Throughput
SPI	Tx – 8 Mbps (TCP), 9 Mbps (UDP) Rx – 5 Mbps (TCP), 6 Mbps (UDP)

The numbers are the actual application throughputs. For physical data rates, please refer to the table [Wireless Specification](#) .

6.4: Range

Range varies with the conditions under which wireless communication is sought. For large office environments, in the presence of obstacles, a range of over 30 metres is observed, while in open, line-of-sight environments, over 300 metres is observed.

6.5: Standards Compliance

RS9110-N-11-24 is compliant with the requirements of IEEE 802.11b, 802.11g, 802.11j, and 802.11n that include the following:

- Transmit Spectral Mask
- Transmit Center Frequency Leakage
- Transmit Center Frequency Tolerance
- Symbol Clock Frequency Tolerance
- Transmit Constellation error
- Receiver Adjacent Channel Interference Rejection
- Receiver Non-adjacent Channel Rejection
- Receiver Minimum Input Level
- Receiver Maximum Input Level

7: Software Architecture Overview

The following figure depicts the software architecture of the RS9110-N-11-24 module.

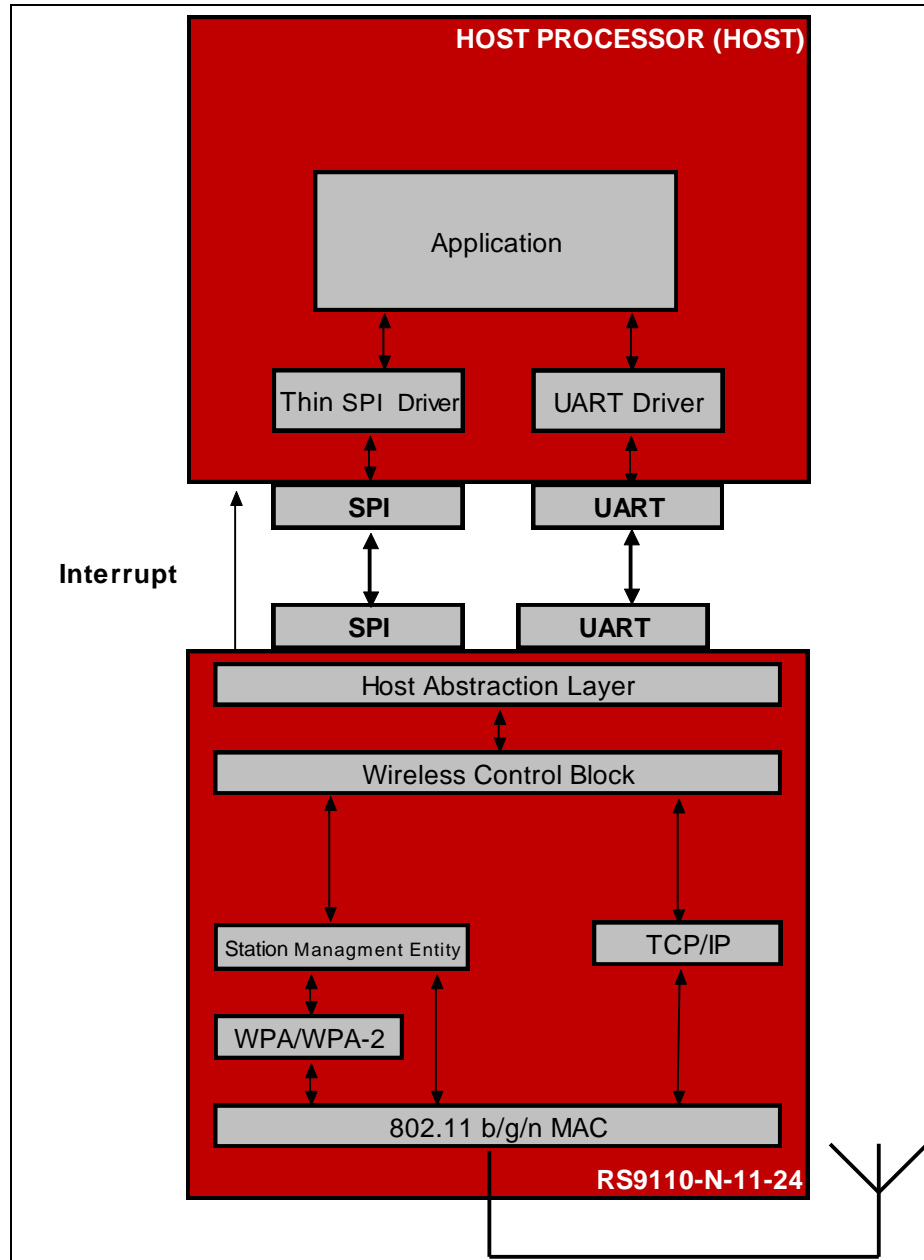

Figure 9: RS9110-N-11-24 Software Architecture Block Diagram

As shown in the figure above, the RS9110-N-11-24 module is integrated with the Host using either UART or SPI interfaces. The transmission and reception of the data to/from the Host depends on the interface used to connect the module as briefed below.

UART mode:

The Host transmits/receives raw data using UART interface when the RS9110-N-11-24 module is configured for UART mode. The access to the TCP/IP stack in the Wi-Fi module through the UART is provided through AT commands.

SPI mode:

Host transmits/receives raw data using SPI interface when the RS9110-N-11-24 module is configured for SPI mode. A thin driver on the Host takes care of interacting with the Wi-Fi module through the SPI Host interface.

The following sections explain in brief the various components illustrated in Figure 9.

7.1: Host

The Host is any system that has applications being executed and either a UART or SPI interface.

7.1.1: UART

The UART on the Host side provides an interface for the host to access the Wi-Fi module. UART is used to configure various parameters of the RS9110-N-11-24 module and also to send and receive data over the network by accessing the TCP/IP stack in the RS9110-N-11-24 module.

7.1.2: SPI

The SPI on the Host side provides an interface for the host to access the Wi-Fi module. SPI on the Host acts as the master.

7.1.3: Thin SPI Driver

The SPI driver on the Host is a thin driver through which the applications interact with the Wi-Fi module. The SPI driver uses the SPI host controller driver on the Host to send/receive the data to/from the RS9110-N-11-24 module and also to configure the same over the SPI interface.

7.2: RS9110-N-11-24

The RS9110-N-11-24 module incorporates Wi-Fi, TCP/IP, DHCP, ARP, etc. to act as a WLAN device. It handles all the network connectivity functions. The following sections describe the software components of the RS9110-N-11-24 module in brief.

7.2.1: SPI

The SPI on the RS9110-N-11-24 acts the SPI slave. It is a standard 4-wire SPI and can support a maximum frequency of 25MHz.

7.2.2: UART

The UART on the RS9110-N-11-24 module is the physical interface which transmits/receives the data from the Host. It supports variable baud rates

from 9600 to 3686400 bps. There is support for AT commands to configure and operate the module through UART interface.

7.2.3: Host Abstraction Layer (HAL)

The HAL abstracts the lower layers in the host interface with which the RS9110-N-11-24 module is connected. The HAL interacts with the Wireless Control Block layer for the processing of the frames obtained from or destined to the Host.

7.2.4: Wireless Control Block (WCB)

The data from/to the Host is classified as Wi-Fi specific frames and TCP/IP specific frames. The WCB layer processes the frame obtained and acts accordingly. The functionality of the WCB module depends on the type of the frame and the direction of the frame (in case of TCP/IP) as described below.

7.2.4.1: TCP/IP Control frames

If the frames from the host are interpreted as TCP/IP specific frames then the WCB interacts with the TCP/IP stack.

7.2.5: Station Management Entity (SME)

The SME is the core layer, which manages the Wi-Fi connectivity. The SME maintains the state machine to detect the activity on the Wi-Fi network and indicates to the user accordingly. It also performs re-association to the configured access point in Infrastructure mode. It interacts with the WPA supplicant if Security is enabled in the Wi-Fi network.

7.2.6: WPA Supplicant

The WPA supplicant is used to initiate the 802.1x/EAP authentication if WPA2-PSK is used as the security parameter. It also plays a major part in performing the 4-way handshake to derive the PTK in WPA2-PSK modes.

7.2.7: Power Save Modes

The RS9110-N-11-2X module supports three power modes. The Host can switch among the power modes depending on the Wi-Fi connection status as defined in this section.

7.2.7.1: Power mode 0

In this mode, power save is disabled in the RS9110-N-11-2X module. The module will be in Power Mode 0 by default.

7.2.7.2: Power mode 1

The RS9110-N-11-2X module powers off the Baseband, RF and also the Core Control block in this mode. To power off the Core Control block, the RS9110-N-11-2X module sends request to Host for permission to sleep.

Once the permission is received the Core Control block is powered off. The Host has to wait for the module to wakeup based on the timer that is configured by the Host, before it can transmit any packets.

The functioning of the module in this mode depends on the connection status as explained below

1. Before Wi-Fi connection

In this state, the module is configured with a sleep timer. Once the timer expires, the module powers on the Core Control block and sends the request for sleep permission to the Host again. On getting permission the Host, the module will power off the Core Control block for another interval of the sleep period.

If the host wants to perform any Wi-Fi related activity like scanning or joining networks, it has to switch to Power Mode 0. After a connection is established, it can switch back to Power Mode 1 or 2.

2. After Wi-Fi Connection

In this state, the RS9110-N-11-2X module periodically wakes up to receive beacons from the Access Point (AP). If there is no data to be transmitted or received to/from the Access Point, it powers off the Baseband and RF components and requests the Host permission to turn off the Core Control block. On receiving permission from the Host, the module goes to sleep and wakes up before the next beacon comes.

7.2.7.3: Power mode 2

The RS9110-N-11-2X module powers off the Baseband and RF components in this mode. The Core Control block interacting with the Host is always functional in this mode. Hence, the module can receive commands from the host at any time.

NOTE: The average current consumption in Power Mode 2 is higher than Power Mode 1.

The functioning of the module in this mode depends on the connection status as explained below

1. Before Wi-Fi connection

If this power mode is enabled before the Wi-Fi connection is established, the module powers off the Baseband and RF components until the Host reconfigures the module to Power Mode 0.

If the host wants to perform any Wi-Fi related activity like scanning and joining networks, it has to switch to Power Mode 0. This can be done at any time during the operation. The Host can switch back to Power Modes 1 or 2 after the Wi-Fi connection is established.

2. After Wi-Fi Connection

In this state, the RS9110-N-11-2X module gets information from the Access Point to which it is connected for any buffered data at every beacon. If there is no data to be transmitted or received to/from the Access Point, it powers off the Baseband and RF components.

8: Ordering Information

Contact Information:

For additional information, please contact Sales at Redpine Signals, Inc.

Redpine Signals, Inc.

2107 North First Street, Suite 680,

San Jose, CA 95131 USA

Phone: +1 408 748 3385

E-mail: sales@redpinesignals.com

Website: <http://www.redpinesignals.com/>

Device Ordering Information:

The following table lists the part numbers to be used for ordering modules or evaluation boards (EVB). Redpine can create and provide customized firmware based on user requirements.

Device Number	Description	Packaging	Qualification
RS9110-N-11-24	Part with UART ¹ as Host interface	Tray	-40 C to +85 C
RS9110-N-11-24-02	Part with SPI as Host interface	Tray	-40 C to +85 C
RS9110-N-11-24-EVB	Evaluation board with UART as Host interface	Tray	-40 C to +85 C
RS9110-N-11-24-02-EVB	Evaluation board with SPI as Host interface	Tray	-40 C to +85 C

Table 7: Device Ordering Information

Collateral:

The following documentation and software are available along with the RS9110-N-11-24 modules or Evaluation Boards (EVB).

- Embedded firmware for WLAN and TCP/IP stack
- AT Command Interface and SPI driver software
- Reference Schematics and Layout Guidelines - Describes hardware schematics to operate the module in UART and SPI modes
- Programming Reference Manual - Describes how to operate the module in UART and SPI modes

Evaluation Board (EVB) and related user guides

¹ TKIP mode of security is not supported in the UART interface module.

9: Command Reference (AT commands and SPI commands)

AT Command Set (for UART interface) and SPI command set (for SPI interface) supports the following in RS9110-N-11-XX module. This is an indicative list and not a full list. The full list of commands is available in the Programming Reference Manual.

- i. Configure the band to 2.4GHz
- ii. Initialize MAC and Baseband
- iii. Scan for available networks
- iv. Join an available network in infrastructure or ad-hoc modes
- v. Configure IP addresses
- vi. Open and close TCP and UDP sockets Send and receive data
